

DATED 6/6/19
SUPERSEDES 1/1/16

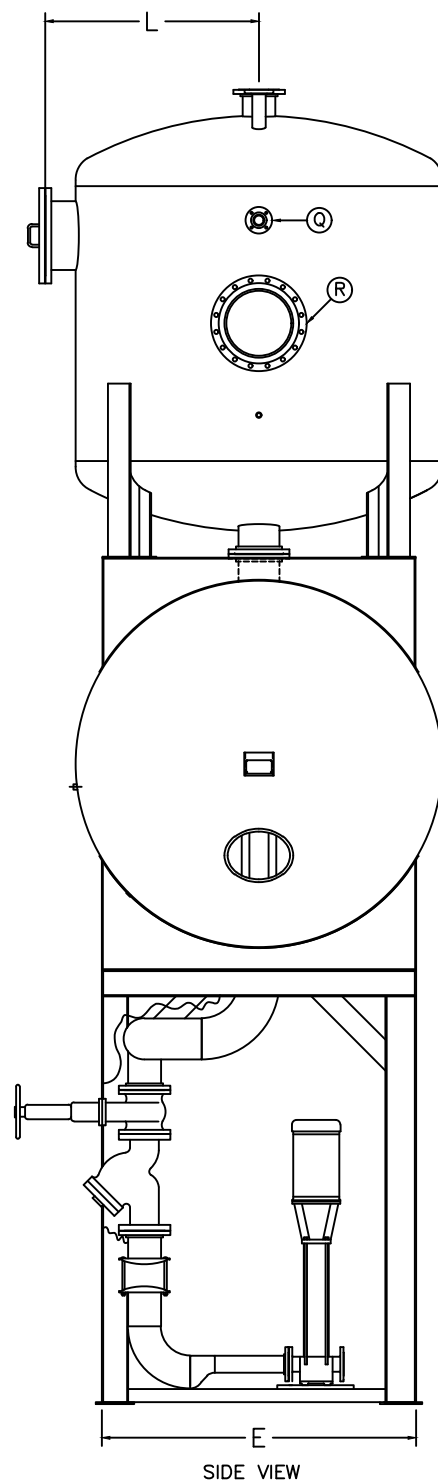
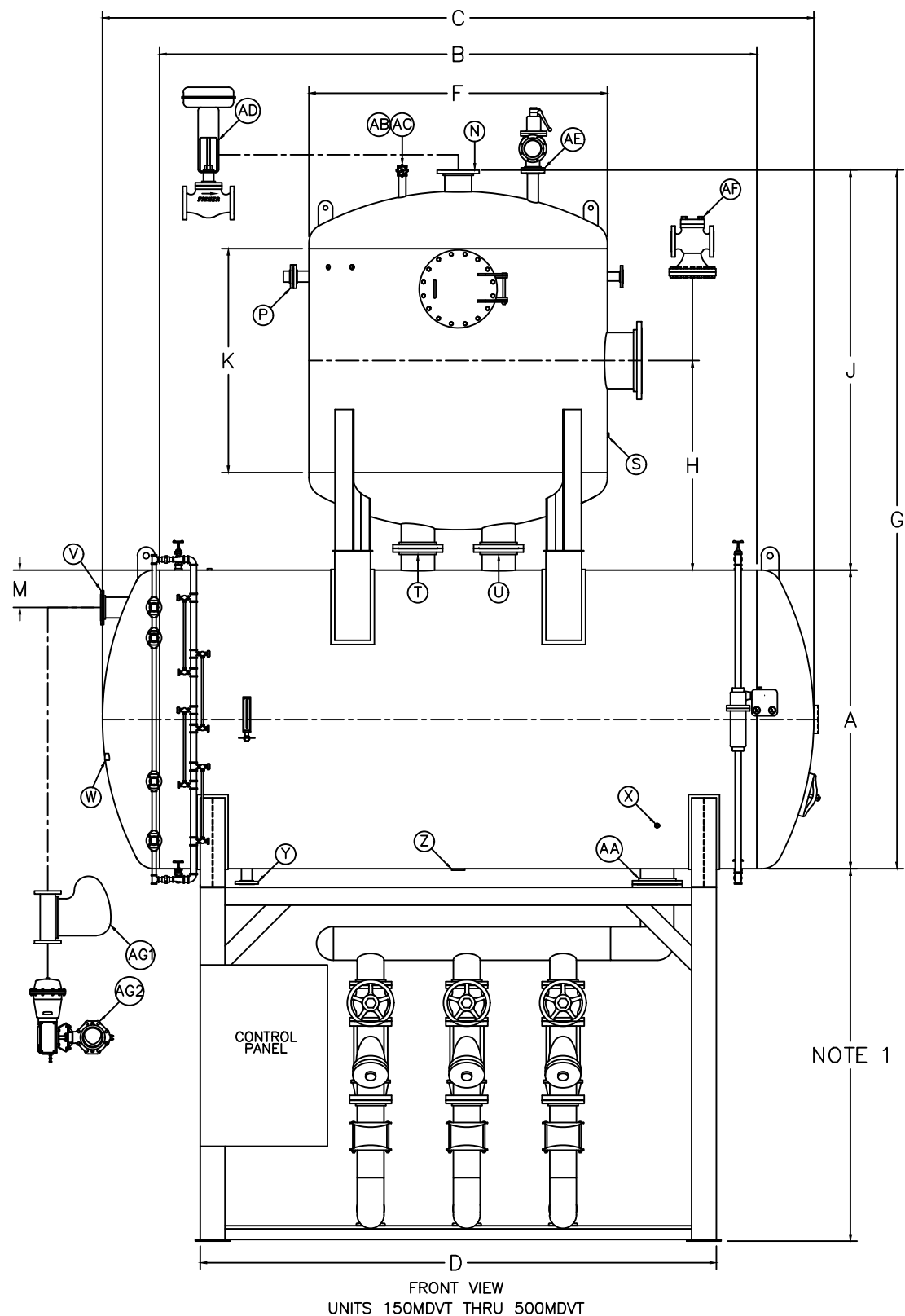

NOTE 1

NOTES

1. DETERMINED BY SPECIFIC PUMP REQUIREMENTS.
2. STORAGE CAPACITY TO OVERFLOW.
3. ALL DIMENSIONS IN INCHES.
4. THIS DRAWING NOT FOR CONSTRUCTION PURPOSES.
5. THIS DRAWING SHOWS BOTH STANDARD AND OPTIONAL EQUIPMENT. ACTUAL EQUIPMENT SUPPLIED WILL DEPEND ON JOB SPECIFIC REQUIREMENTS.
6. AG1, MECHANICAL OVERFLOW TRAP, FOR 350MDVT AND SMALLER.
AG2, PNEUMATIC ROTARY VALVE, FOR 400MDVT AND LARGER.

MODEL NO.	150MDVT	175MDVT	200MDVT	250MDVT	300MDVT	350MDVT	400MDVT	450MDVT	500MDVT
CAP-LBS/HR	150,000	175,000	200,000	250,000	300,000	350,000	400,000	450,000	500,000
STORAGE CAPACITY (NOTE 2)	MINUTES	10	10	10	10	10	10	10	10
	GALLONS	3000	3500	4000	5000	6000	7000	8000	10000
A STORAGE DIAMETER	84	84	84	96	96	102	108	120	120
B STORAGE STRAIGHT LENGTH	120	144	156	156	192	192	192	168	192
C (APPROX)	155	179	191	193	229	228	234	211	235
D STAND LENGTH	96	120	132	132	168	168	168	144	168
E STAND WIDTH	72	72	72	84	84	84	90	102	102
F DEAERATOR DIAMETER	72	78	78	90	96	96	102	120	120
G (APPROX)	192	192	192	212	225	231	236	254	254
H	58	58	58	62	67	67	67	70	70
J (APPROX)	108	108	108	116	129	129	128	134	134
K DEAERATOR STRAIGHT LENGTH	60	60	60	60	72	72	72	72	72
L (APPROX)	44	47	47	53	56	56	59	68	68
M	9	9	9	12	12	12	12	12	12
N MAKE-UP WATER INLET	4	6	6	6	6	6	8	8	8
P VACCUM BREAKER	3	3	3	3	3	3	3	3	3
Q HIGH TEMP RETURNS	2 1/2	2 1/2	2 1/2	2 1/2	2 1/2	2 1/2	2 1/2	2 1/2	2 1/2
R STEAM INLET	12	14	14	16	18	18	20	20	24
S PRV SENSING	3/4	3/4	3/4	3/4	3/4	3/4	3/4	3/4	3/4
T EQUALIZER	6	6	8	8	10	10	10	12	12
U DOWNCOMER	6	6	8	8	10	10	12	12	12
V OVERFLOW	4	6	6	6	6	6	8	8	8
W CHEMICAL INJECTION x2	1 1/4	1 1/4	1 1/4	1 1/4	1 1/4	1 1/4	1 1/4	1 1/4	1 1/4
X SAMPLE	3/4	3/4	3/4	3/4	3/4	3/4	3/4	3/4	3/4
Y RECIRC.	2	2	2	3	3	4	4	4	4
Z VESSEL DRAIN	2 1/2	2 1/2	2 1/2	2 1/2	3	3	3	3	3
AA SUCTION	8	8	8	10	10	10	10	12	12
AB VENT VALVE	2	2	2	2	2	2	2	2	2
AC VENT ORFICE	3/8	3/8	3/8	1/2	1/2	1/2	1/2	1/2	1/2
AD WATER INLET VALVE									
AE SENTINEL RELIEF VALVE	3	3	3	3	3	3	3	3	3
AF STEAM PRESS. REDUCING VALVE	SIZE ON APPLICATION								
AG OVERFLOW TRAP/ VALVE(SEE NOTE)	4	6	6	6	6	6	8	8	8

bfs INDUSTRIES, LLC
BUTNER, NORTH CAROLINA

150MDVT THRU 500MDVT CLASS "T" DIMENSIONS
PACKAGED TRAY TYPE DEAERATOR