

FRONT VIEW
UNITS 150MS THRU 500MS

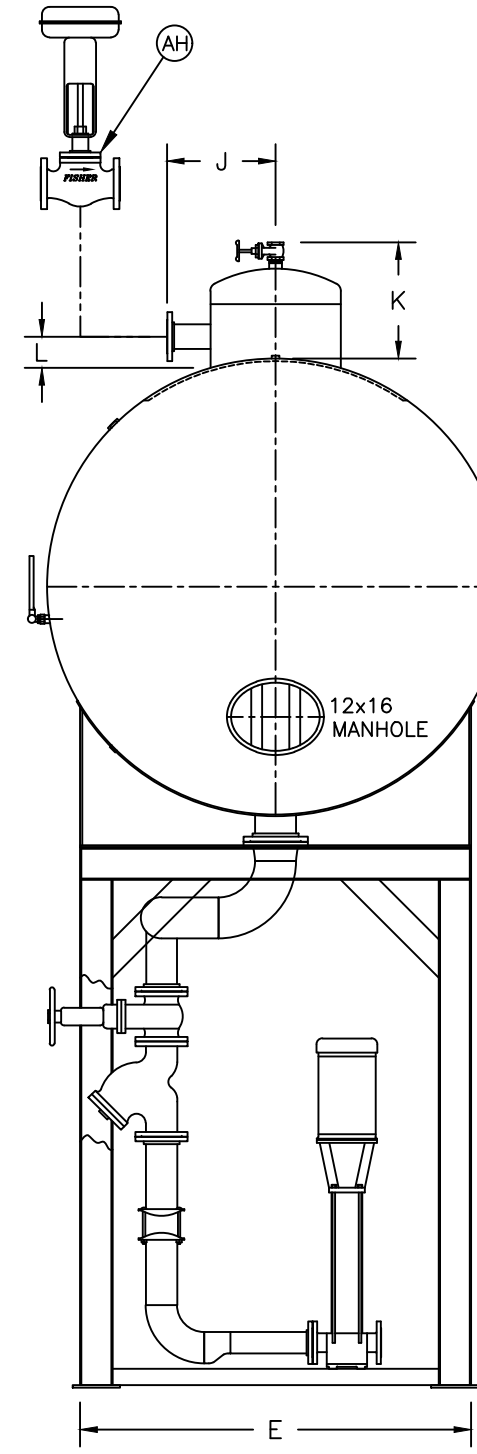

SIDE VIEW

MODEL NO.	150MS	175MS	200MS	250MS	300MS	350MS	400MS	450MS	500MS
CAP-LBS/HR	150,000	175,000	200,000	250,000	300,000	350,000	400,000	450,000	500,000
STORAGE CAPACITY (NOTE 2)	MINUTES	10	10	10	11	11	10	11	10
	GALLONS	3,000	3,500	4,000	5,500	6,500	7,000	8,500	10,000
A DIAMETER	84	84	84	96	96	102	108	108	120
B STRAIGHT LENGTH	144	180	204	192	240	216	216	240	216
C (APPROX)	179	215	239	229	277	252	258	282	258
D STAND LENGTH	120	156	180	168	216	192	192	216	192
E STAND WIDTH	72	72	72	78	78	86	90	90	102
F	110	122	140	128	158	145	133	157	145
G	24	24	24	27	27	27	27	27	27
H	35	47	65	53	83	70	58	82	70
J	20	20	20	23	23	23	23	23	23
K (APPROX)	21	21	21	22	22	22	22	22	23
L (APPROX)	6	6	6	6	6	6	6	6	6
M	24	24	24	24	24	24	24	24	24
N VACUUM BREAKER	3	3	3	3	3	3	3	3	3
P OVERFLOW	4	6	6	6	6	6	8	8	8
R RECIRC	2	2	2	3	3	4	4	4	4
S STEAM INLET	12	14	14	16	18	18	20	20	24
T PUMP SUCTION	8	8	8	10	10	10	10	12	12
U MAKE-UP WATER INLET	4	6	6	6	6	6	8	8	8
V MEDIUM TEMP RETURNS	2 1/2	2 1/2	2 1/2	2 1/2	2 1/2	2 1/2	2 1/2	2 1/2	2 1/2
W HIGH TEMP RETURNS	2 1/2	2 1/2	2 1/2	2 1/2	2 1/2	2 1/2	2 1/2	2 1/2	2 1/2
X PRV SENSING	3/4	3/4	3/4	3/4	3/4	3/4	3/4	3/4	3/4
Y SAMPLE	3/4	3/4	3/4	3/4	3/4	3/4	3/4	3/4	3/4
Z CHEMICAL INJECTION	1 1/4	1 1/4	1 1/4	1 1/4	1 1/4	1 1/4	1 1/4	1 1/4	1 1/4
AA VESSEL DRAIN	2 1/2	2 1/2	2 1/2	2 1/2	3	3	3	3	3
AB SCRUBBER DRAIN	3/4	3/4	3/4	3/4	3/4	3/4	3/4	3/4	3/4
AC VENT VALVE	2	2	2	2	2	2	2	2	2
AD VENT ORIFICE	3/8	3/8	3/8	1/2	1/2	1/2	1/2	1/2	1/2
AE SENTINEL RELIEF VALVE	3	3	3	3	3	3	3	3	3
AF STEAM PRESS. REDUCING VALVE	SIZE ON APPLICATION								
AG OVERFLOW TRAP/VALVE (SEE NOTE)	4	6	6	6	6	6	8	8	8
AH WATER INLET VALVE									

NOTES

1. DETERMINED BY SPECIFIC PUMP REQUIREMENTS.
2. STORAGE CAPACITY TO OVERFLOW.
3. ALL DIMENSIONS IN INCHES.
4. THIS DRAWING NOT FOR CONSTRUCTION PURPOSES.
5. THIS DRAWING SHOWS BOTH STANDARD AND OPTIONAL EQUIPMENT. ACTUAL EQUIPMENT SUPPLIED WILL DEPEND ON JOB SPECIFIC REQUIREMENTS.
6. AG1, MECHANICAL OVERFLOW TRAP, FOR 350MS AND SMALLER.
AG2, PNEUMATIC ROTARY VALVE, FOR 400MS AND LARGER.

BFS INDUSTRIES, LLC
BUTNER, NORTH CAROLINA

150MS THRU 500MS CLASS "S" DIMENSIONS
PACKAGED SPRAY TYPE DEAERATOR