

FRONT VIEW
UNITS 3.5MS THRU 125MS

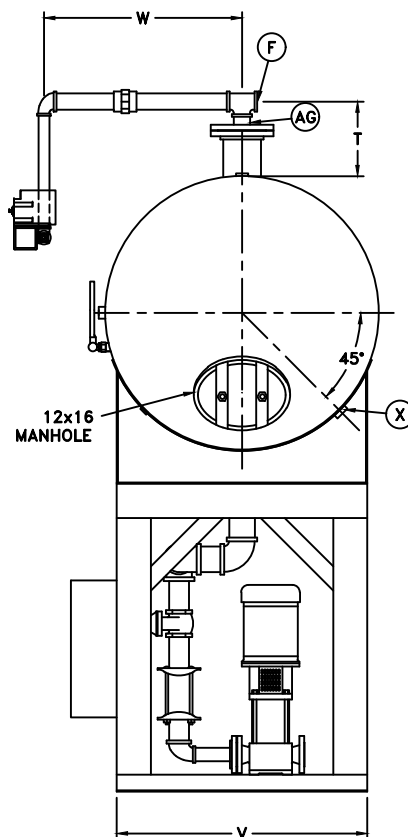

SIDE VIEW

MODEL NO.	3.5MS	5MS	7MS	9MS	11MS	14MS	18MS	21MS	24MS	30MS	40MS	50MS	70MS	80MS	90MS	100MS	125MS	
CAP-LBS/HR	3,500	5,000	7,000	9,000	11,000	14,000	18,000	21,000	24,000	30,000	40,000	50,000	70,000	80,000	90,000	100,000	125,000	
STORAGE CAPACITY (NOTE 2)	MINUTES	21	16	11	12	10	20	15	13	12	11	12	10	11	10	10	11	
	GALLONS	155	155	155	234	234	563	563	563	563	686	1024	1024	1627	1627	1964	1964	2850
A	STEAM SPACE	18	18	18	18	18	18	18	18	18	18	18	18	18	18	18	18	
B	WATER INLET MOTORIZED VALVE	1/2	1/2	1/2	1/2	1/2	3/4	3/4	3/4	1	1	1	1	1 1/4	1 1/4	1 1/4	1 1/4	
C	STEAM INLET	3	3	3	3	3	6	6	6	6	8	8	8	10	10	10	10	
D	OVERFLOW	2	2	2	2	2	2	2	2	2	3	3	3	3	3	3	4	
E	HIGH TEMP RETURNS	1	1	1	1	1	1 1/4	1 1/4	1 1/4	1 1/4	1 1/2	1 1/2	1 1/2	1 1/2	1 1/2	2 1/2	2 1/2	
F	LOW TEMP RETURNS	1	1	1	1	1 1/2	2	2	2 1/2	2 1/2	2 1/2	2 1/2	3	3	3	4	4	
G	MEDIUM TEMP RETURNS	1	1	1	1	1	1 1/4	1 1/4	1 1/4	1 1/4	1 1/2	1 1/2	2	2	2	2 1/2	2 1/2	
H	VENT	3/4	3/4	3/4	3/4	3/4	3/4	3/4	3/4	3/4	1 1/2	1 1/2	1 1/2	1 1/2	1 1/2	2	2	
J	VESSEL DRAIN	3/4	3/4	3/4	3/4	3/4	1	1	1	1	2	2	2	2	2	2 1/2	2 1/2	
K	SCRUBBER DRAIN	—	—	—	—	—	3/4	3/4	3/4	3/4	3/4	3/4	3/4	3/4	3/4	3/4	3/4	
L	DIAMETER	36	36	36	36	36	48	48	48	48	60	60	72	72	72	72	84	
M	STRAIGHT LENGTH	60	60	60	96	96	96	96	96	120	96	96	96	96	120	120	120	
N	(APPROX)	78	78	78	114	114	117	117	117	147	128	128	130	130	154	154	156	
P		20	20	20	20	20	30	30	30	30	33	33	33	33	36	36	36	
R		9	9	9	9	9	9	9	9	9	15	15	15	15	18	18	18	
S		31	31	31	45	45	18	18	18	18	30	21	21	21	21	30	30	24
T	(APPROX)	14	14	14	14	14	14	14	14	14	19	19	19	19	19	19	19	22
U	STAND LENGTH	59	59	59	60	60	80	80	80	80	86	84	84	84	84	96	96	96
V	STAND WIDTH	30 1/2	30 1/2	30 1/2	30 1/2	30 1/2	44	44	44	44	56	56	66	66	66	66	72	
W	(APPROX)	33	33	33	33	33	39	39	39	39	45	45	51	51	51	51	57	
X	RECIRC	3/4	3/4	3/4	3/4	3/4	3/4	3/4	3/4	3/4	1 1/2	1 1/2	1 1/2	1 1/2	1 1/2	1 1/2	1 1/2	
Y	SENTINEL RELIEF VALVE	1	1	1	1	1	1	1	1	1	1	1	1	1	1	1	1	
Z	VACUUM BREAKER	1 1/2	1 1/2	1 1/2	1 1/2	1 1/2	2	2	2	2	2 1/2	2 1/2	2 1/2	2 1/2	3	3	3	
AA	CHEMICAL INJECTION	1 1/4	1 1/4	1 1/4	1 1/4	1 1/4	1 1/4	1 1/4	1 1/4	1 1/4	1 1/4	1 1/4	1 1/4	1 1/4	1 1/4	1 1/4	1 1/4	
AB	SAMPLE	3/4	3/4	3/4	3/4	3/4	3/4	3/4	3/4	3/4	3/4	3/4	3/4	3/4	3/4	3/4	3/4	
AC	PUMP SUCTION	3	3	3	3	3	4	4	4	4	6	6	6	6	6	8	8	
AD	PRV SENSING	3/4	3/4	3/4	3/4	3/4	3/4	3/4	3/4	3/4	3/4	3/4	3/4	3/4	3/4	3/4	3/4	
AE	OVERFLOW TRAP	1 1/2	1 1/2	2	2	2	2	2	2	2	2	3	3	3	3	3	4	
AF	VENT ORFICE	1/8	1/8	1/8	1/8	1/8	1/4	1/4	1/4	1/4	1/4	1/4	5/16	5/16	5/16	5/16	5/16	
AG	MAKE-UP WATER INLET	1 1/2	1 1/2	1 1/2	1 1/2	1 1/2	2 1/2	2 1/2	2 1/2	2 1/2	2 1/2	2 1/2	2 1/2	3	3	3	4	
AH	RV PROVISION TANK CONNECTION	1 1/2	1 1/2	1 1/2	2	2	3	3	3	3	3	3	3	3	3	3	3	

NOTES

1. DETERMINED BY SPECIFIC PUMP REQUIREMENTS.
2. STORAGE CAPACITY TO OVERFLOW.
3. "X" LOCATED FAR SIDE.
4. ALL DIMENSIONS IN INCHES.
5. THIS DRAWING NOT FOR CONSTRUCTION PURPOSES.
6. THIS DRAWING SHOWS BOTH STANDARD AND OPTIONAL EQUIPMENT. ACTUAL EQUIPMENT SUPPLIED WILL DEPEND ON JOB SPECIFIC REQUIREMENTS.

bfs INDUSTRIES, LLC
BUTNER, NORTH CAROLINA

3.5MS THRU 125MS CLASS "S" DIMENSIONS
PACKAGED SPRAY TYPE DEAERATOR